

YAMAHA BREATH CONTROLLER BC2

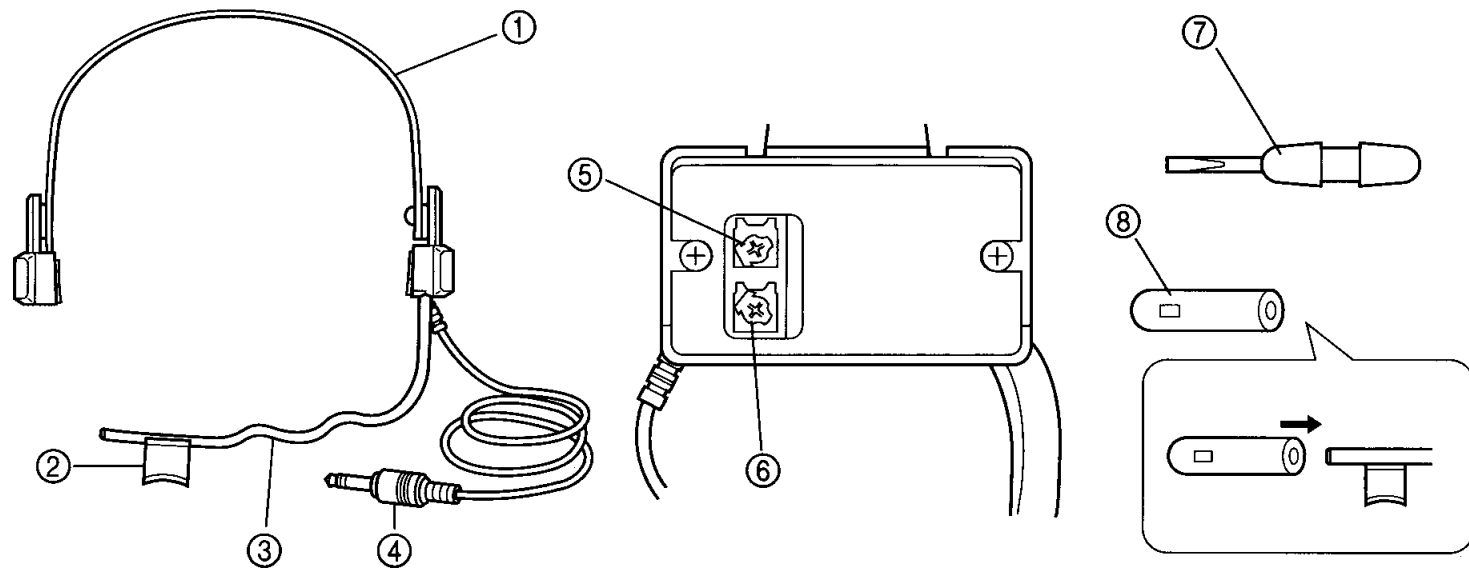

Thank you for purchasing Yamaha's BC2 Breath Controller. The BC2 can be connected to a synthesizer or MIDI keyboard and is able to control MIDI Breath Control data, according to the strength of your breath.

Please read the following descriptions of the illustration, and check the operating instructions.

- ① **Headset** This allows you to wear the breath controller on your head, like headphones.
- ② **Mouthpiece** Blow into this part. The mouthpiece can also be washed after removing it from the pipe (pulling it off). If the drain cap ⑧ is used at the end of the mouthpiece pipe, you can alter the amount of breath necessary to control the data, from a little to a lot.
- ③ **Pipe** Since the pipe moves freely, you can move it to the position where the mouthpiece can most easily be used. However, take care with it, as it may break if bent too far or too often.
- ④ **Connecting plug** This plugs into the Breath Controller terminal of the synthesizer or MIDI keyboard.
- ⑤ **Offset screw** This screw controls the data value that is output when you are not blowing into the controller. Turn the screw clockwise for a higher output.
- ⑥ **Gain screw** This screw controls how sensitive the unit is to your breath. Turn the screw clockwise for a higher sensitivity (a larger change in the data, with less breath).
- ⑦ **Screwdriver** This screwdriver can be used to adjust the offset screw and the gain screw.
- ⑧ **Drain cap** This cap changes the size of the outlet at the end of the pipe in the mouthpiece section. This allows you to adjust the amount of air that passes through. If it is pushed in as far as possible, no air will pass through.

- When first shipped from the factory, the offset and the gain screws are set at standard positions.
- If the drain cap is only slightly pressed in, it is possible that the air pressure produced by blowing into the mouthpiece will be enough to blow the cap out. Please take special care if only partially inserting the drain cap.