

Thank you for purchasing the Yamaha ELECTRONIC DRUM KIT DTX8K-X or DTX8K-M. This electronic drum kit can be used in your home or a studio, or onstage for live performances. For proper assembly and safe use, read this assembly manual carefully before using it. After you have read the manual, keep it in a safe and handy place for future reference. This manual describes the standard assembly procedure for the DTX8K-X/DTX8K-M electronic drum kits. It covers assembly, wiring and setting up the drum trigger module of the kit. The illustrations show the DTX8K-X electronic drum kit, but the information applies to the DTX8K-M (except where indicated).

Example of standard assembly

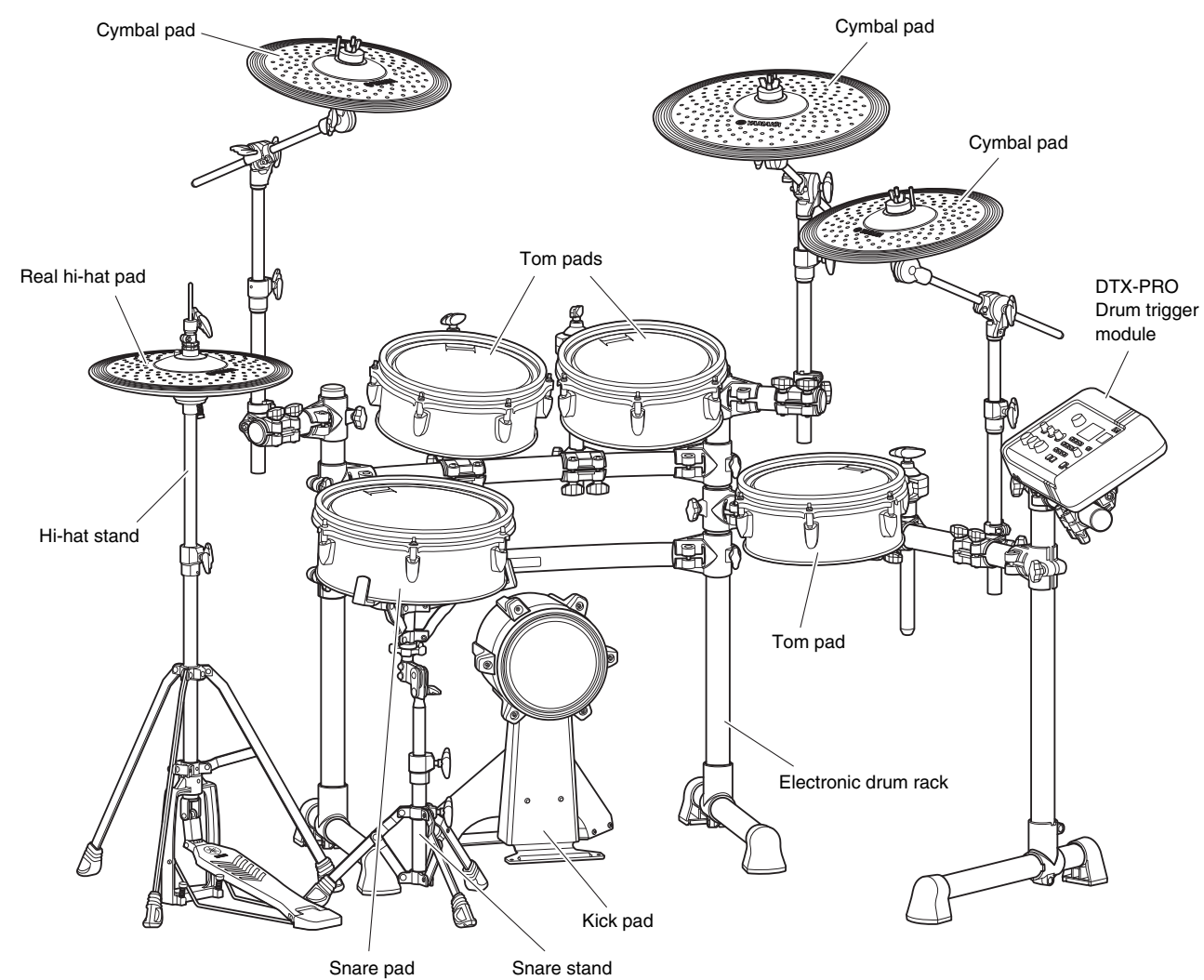

IMPORTANT

This manual describes the process of assembling a pad set and drum trigger module to an already assembled RS8 Electronic Drum Rack. Before starting the steps below, therefore, be sure to assemble your RS8 as described in the Owner's Manual that came with it.

NOTICE

Lay a drum mat (sold separately) on the floor underneath the hi-hat stand and the kick pad. Alternatively, you can place cardboard from the drum kit packaging or the like on the floor to prevent it from being scratched.

1 Open the boxes to reveal their contents.

After opening up the packages containing your electronic drum kit, verify that all of the following components are present.

Components of both DTX8K-X and DTX8K-M

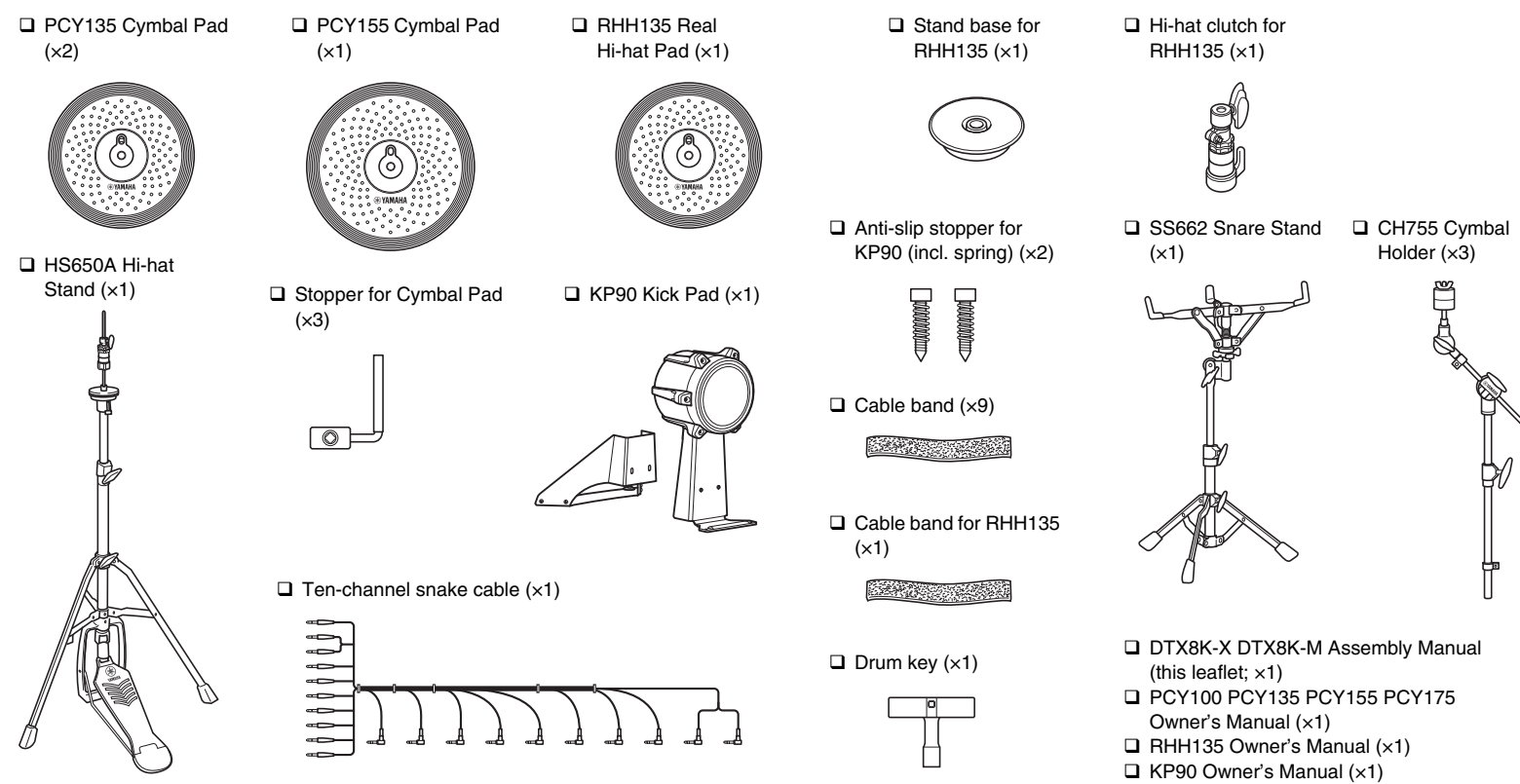

DTX8K-X only

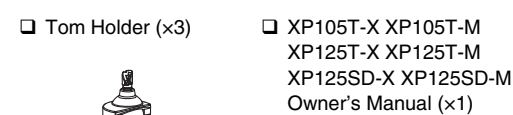

DTX8K-M only

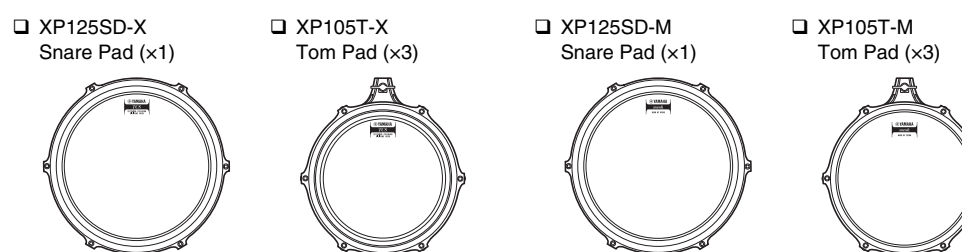

2 Assemble the RS8 Electronic Drum Rack.

For instructions on how to assemble the RS8 Electronic Drum Rack, refer to the Owner's Manual that came with it.

3 Assemble the pads and the drum trigger module to the electronic drum rack.

PRECAUTIONS Please read carefully before proceeding

The purpose of the precautions detailed below is to ensure that this electronic drum kit can be used safely without fear of injury or property damage. Precautions are extremely important in terms of ensuring safety, and therefore, they should be fully observed.

- * After reading this Assembly Manual, ensure that it is kept in a safe, convenient location for future reference.
- * Be sure to also read the Assembly Manuals and/or Owner's Manuals that came with your pads and rack.

CAUTION	Failure to observe the precautions described below can result in injury and/or property damage.
• Assemble this product in the proper sequence by following the assembly instructions in this manual. Also, make sure to tighten the bolts regularly. Failure to do so might result in damage to the product or even injury.	
• Do not let small children assemble or set up this product by themselves, or they can be injured. Always assemble this product with adult supervision.	
• Be careful with the edges of the cymbal holders and the tom holders. The sharp holder ends can result in injury.	
• The anti-slip stoppers on kick pads and on foot pedals have sharp tips. In order to avoid injury, therefore, you should take special care whenever handling these components.	
• Be sure to securely tighten bolts and other fasteners when setting up this product. In addition, be sure to proceed slowly when loosening bolts. If this precaution is not observed, pads can fall off or the rack can collapse or fall over, possibly causing injury.	
• Do not place the product in an unstable position where it might accidentally fall over.	
• Whenever setting up this electronic drum kit, ensure that cables and the like are arranged safely. If someone were to trip on a cable, the kit could topple over and cause injury.	
• Do not alter the product. Doing so can result in injury or damage/deterioration to the product.	
• Do not sit or step on the rack. The rack can overturn or be damaged, resulting in injury.	

* The illustrations as shown in this manual are for instructional purposes only, and may appear somewhat different from those on your product.
* The company names and product names in this manual are the trademarks or registered trademarks of their respective companies.
* The contents of this manual apply to the latest specifications as of the publishing date. To obtain the latest manual, access the Yamaha website then download the manual file. Since specifications, equipment or separately sold accessories may not be the same in every locale, please check with your Yamaha dealer.

CAUTION	Failure to observe the precautions described below can result in injury and/or property damage.
• Be careful with your fingers and hands when adjusting clamps, to prevent them from becoming pinched and injured.	
• Be careful around pipe ends and inside. Metal shavings, etc. can injure your fingers and hands.	
• Do not place hands or feet under a hi-hat stand, kick pad or foot pedal. Doing so could result in injury.	
• Do not attach acoustic drums to the electronic drum rack. Clamps can be damaged and drums can drop, causing injury.	
• Keep small parts out of the reach of infants. Your children may accidentally swallow them.	
• Do not go near the product during an earthquake. Strong shaking during an earthquake could cause the product to move or tip over, resulting in damage to the product or its parts, and possibly causing injury.	
• When transporting or moving the product, always use two or more people. Attempting to lift the product by yourself may damage your back, result in other injury, or cause damage to the product itself.	

NOTICE: Usage Precautions

- When connecting and disconnecting cables, be sure to hold the plug and not the cable itself. In addition, avoid placing heavy items on top of cables and do not allow them to touch sharp edges. Failure to avoid these precautions can lead to cable breakage and disconnection.
- Do not climb onto the electronic drum kit and avoid placing heavy objects on it. Failure to observe this precaution can result in malfunction.
- Do not use or keep the product in places with extremely high temperature (places in direct sunlight, close to a heater, in a closed car, etc.) or high humidity (bathroom, outside on a rainy day, etc.). Doing so can result in deformation, discoloration, damage or deterioration.
- When cleaning the product, use a soft and dry/slightly damp cloth. Do not use paint thinners, solvents, alcohol, cleaning fluids, or chemical-impregnated wiping cloths.

Assembling the cymbal holders

1. Assemble the cymbal holders (CH755 x 3) on the electronic drum rack as shown below, and then tighten the clamp bolt to secure the holder in place.

NOTE
You can change the position of a position clamp to mark the settings for future setups and to prevent unintentional changes during musical performances. Make sure to secure the position clamp using the drum key after moving the clamp.

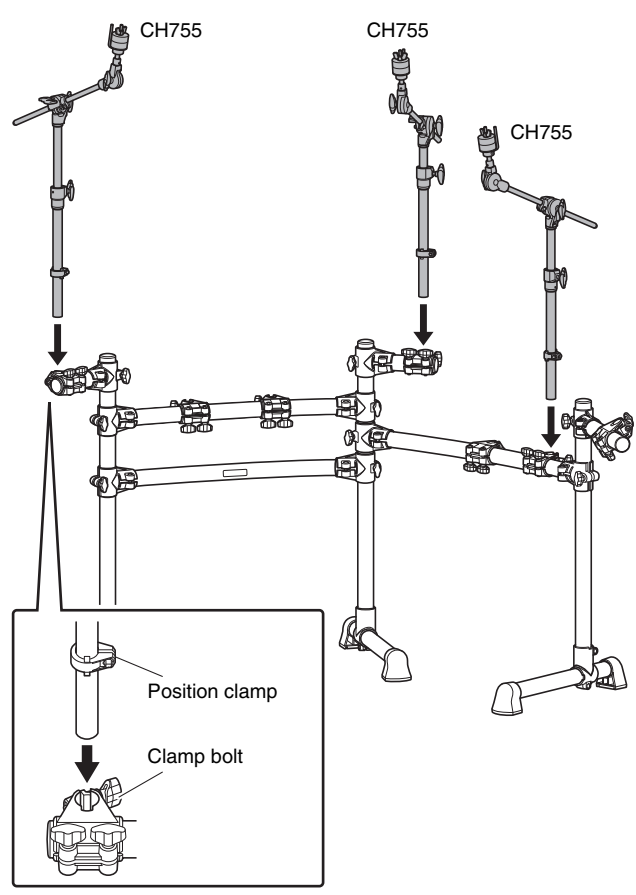

Assembling the tom pads

1. Assemble the tom holders (x3) on the electronic drum rack as shown above, and then tighten the clamp bolt to secure the holder in place.

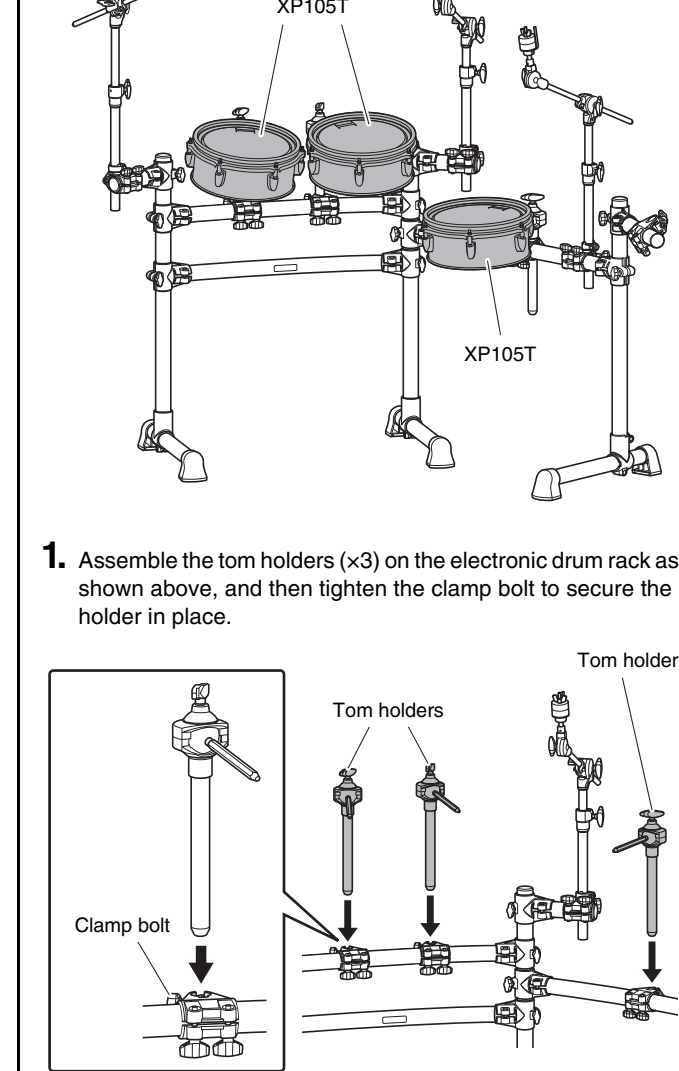

2. Push the tom pads onto the tom holder's rods. Leave a gap of about a half inch between the base of the tom holder and the tom pad, and then tighten the wing bolt to secure the pad in place.

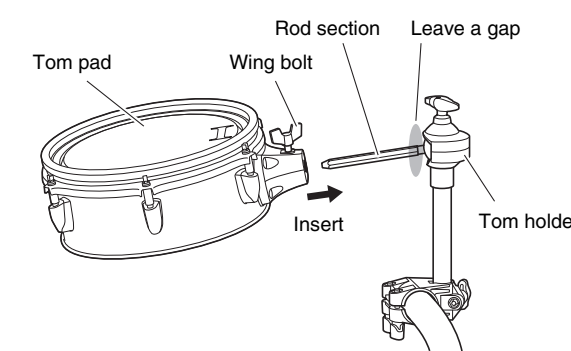

3. Loosen wing bolts A to B and clamp bolts C to E as shown below to adjust the height and angle of any of the pads. When correctly positioned, be sure to securely retighten the bolts before proceeding to the next step.

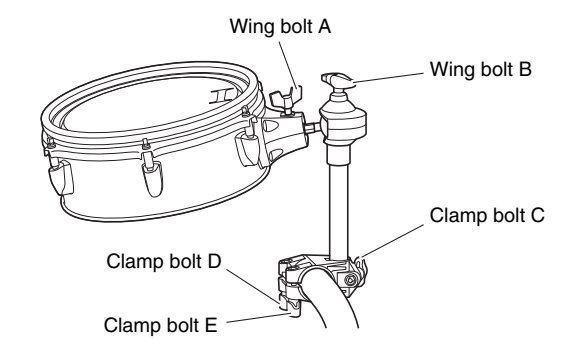

NOTICE

Before every playing, tighten the drum key bolts so that there is no rattling and loosening of the head. In order to prevent malfunction. Refer to the "Head tension adjustment" in the XP105T-X XP105T-M XP125T-X XP125T-M XP125SD-X XP125SD-M Owner's Manual.

Assembling the hi-hat stand

1. If a drum mat (sold separately) is not available, lay a sheet of cardboard on the floor to prevent it from being scratched.
2. Loosen the hi-hat stand's wing bolt **Ⓐ**.
3. Open up the three legs as shown below and then retighten the wing bolt **Ⓐ** to lock them in place.
4. Insert the footboard stabilizer rods into the frame holes as shown below.

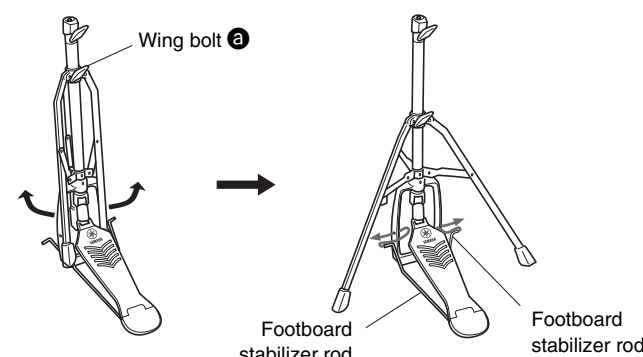

5. Loosen the hi-hat clutch's wing bolt **Ⓑ** and remove the hi-hat clutch.
 - * The hi-hat clutch is not required when assembling the electronic drum kit in the standard fashion described in this manual. Instead, the hi-hat clutch that came with the RHH135 Real Hi-hat Pad will be used.
6. Remove the hi-hat shaft **Ⓑ** from the upper tube **Ⓐ**.
7. Insert the hi-hat shaft **Ⓑ** removed in Step 6 as far as it will go into the lower tube **Ⓒ** and screw in the tip.
8. Insert the upper tube **Ⓐ** over the hi-hat shaft **Ⓑ** and tighten the wing bolt **Ⓒ** to secure it in place with the cymbal support approximately half way between the top of the lower tube **Ⓒ** and the top of the hi-hat shaft **Ⓑ**.
9. Remove the felt washer attached above the cymbal support.
 - * Do not remove the Metal washer.
 - * The felt washer is not used when assembling the electronic drum kit in the standard fashion described in this manual. If you leave it on, you will not be able to get the proper playing feeling, so be sure to remove it.

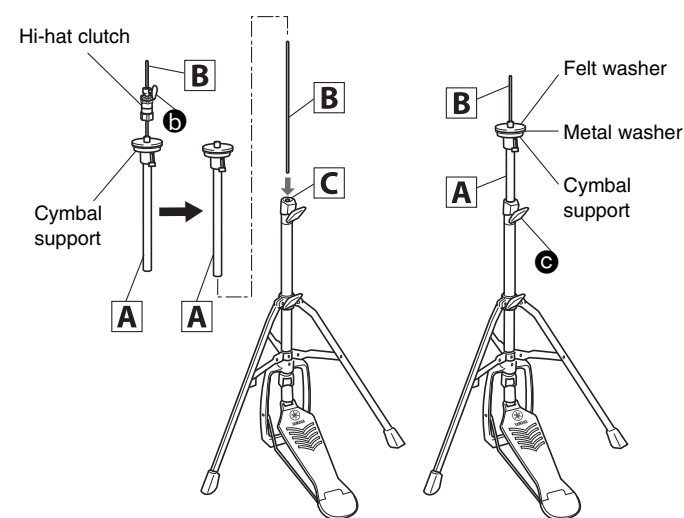

10. Assemble the RHH135 Real Hi-hat Pad.
 - * For detailed instructions, refer to the "Setting Up" in the RHH135 Owner's Manual.

Assembling the drum trigger module and cymbal pads

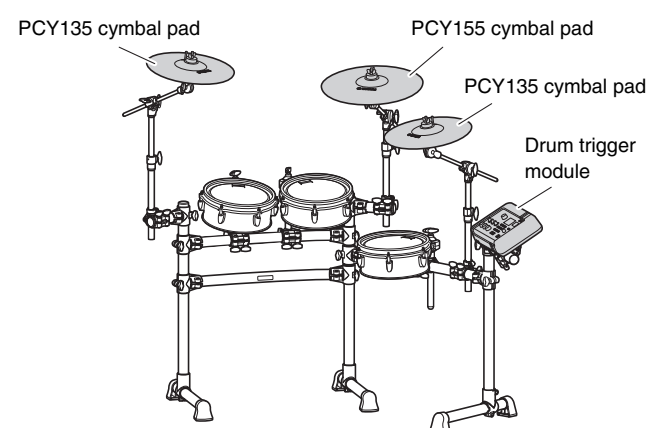

■ Drum trigger module

1. Secure the module holder to the bottom of the drum trigger module using the module holder screws.

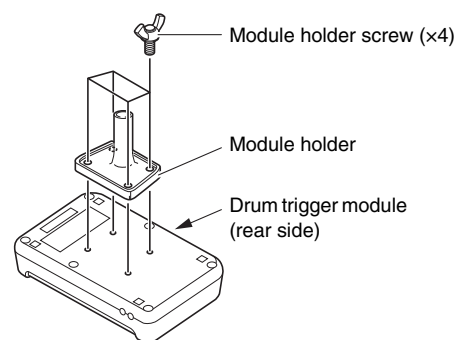

2. Push the module holder into the holder clamp and tighten the clamp bolt to secure it in place.

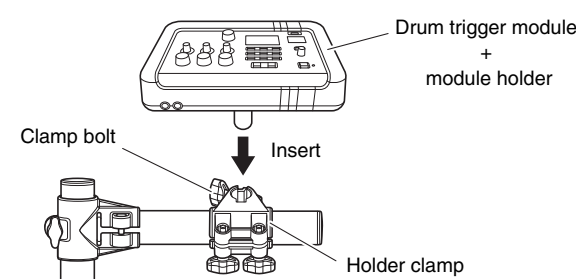

■ Cymbal pads

1. Using the drum key, loosen the stopper's key bolt.

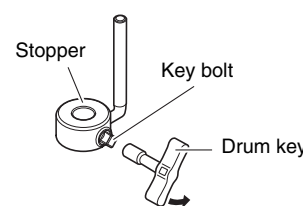

2. Remove the wing nut, the two felt pads, and the bolt cover from the cymbal holder.

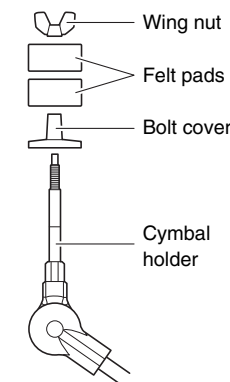

3. Place the stopper on the cymbal holder.

- * If the key bolt was not sufficiently loosened in Step 1 above, the cymbal holder may not pass through the hole of the stopper. In such a case, loosen the key bolt as much as possible without removing it.

4. Replace the bolt cover.

- * Turn the bolt cover to tighten it onto the threaded section and firmly secure it in place.

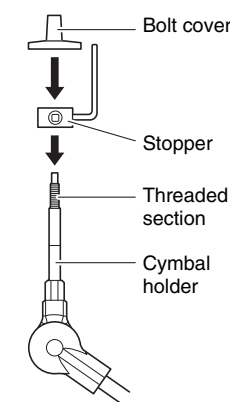

5. With the stopper making full contact with the bottom surface of the bolt cover as shown below, tighten the stopper's key bolt using the drum key.

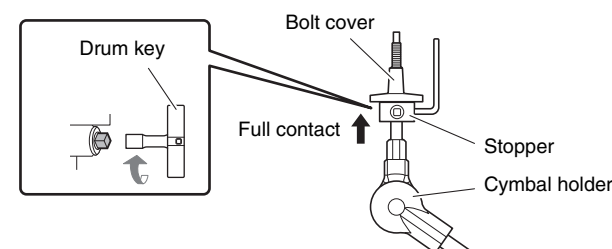

6. Place one of the felt pads removed in Step 2 on the cymbal holder.

7. Mount the pad on the cymbal stand. Lower the pad into place with the cymbal holder's shaft passing through the central hole. When mounted, the stopper's pin should rest inside the pad's smaller hole.

- * Playing your pad unit without the stopper's pin positioned fully inside the smaller hole could cause slip out of the hole. It is very important, therefore, to ensure that the stopper is secured as shown in Step 5 above.

8. Assemble the other felt pad removed in Step 2 to the cymbal holder.

9. Tighten the wing nut to secure the pad to the cymbal holder.

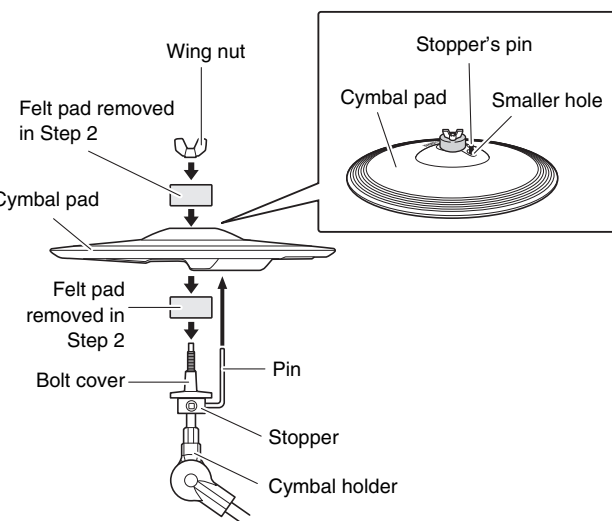

Assembling the kick pad

1. If a drum mat (sold separately) is not available, lay a sheet of cardboard on the floor to prevent it from being scratched.
2. Remove the two wing bolts from the kick pad frame, and then place them nearby.
3. Join the base to the frame as shown on the below, and then secure it in place by the wing bolts removed in the previous step from the base side.

NOTE

For details on assembling the foot pedal (sold separately), refer to the "Assembling the KP90" in the KP90 Owner's Manual.

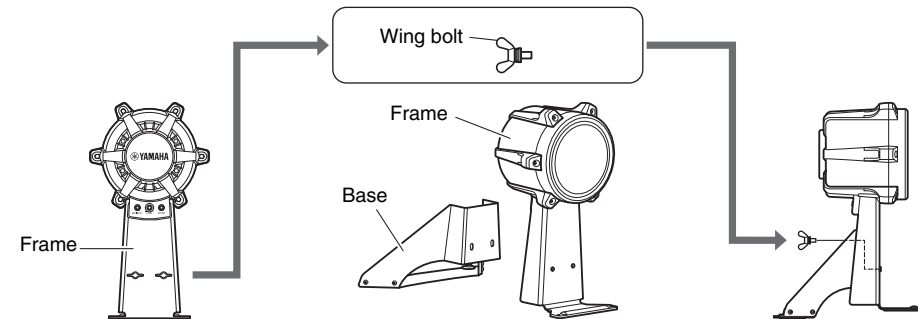

Assembling the Snare Stand and Snare Pad

1. Open up the snare stand's legs and stand it up on the floor.
2. Open up the snare stand's basket section, lay the Snare Pad on it, adjust the basket, and then tighten the adjusting knob to secure the pad and prevent it from moving.

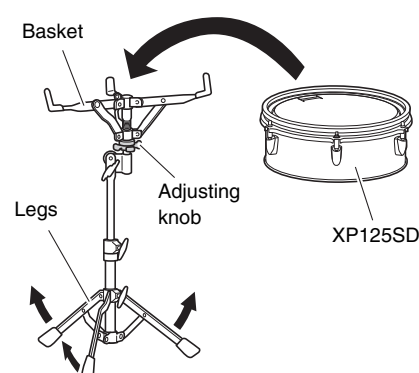

NOTE

Before every playing, tighten the drum key bolts so that there is no rattling and loosening of the head, in order to prevent malfunction. Refer to the "Head tension adjustment" in the XP105T-X XP105T-M XP125T-X XP125T-M XP125SD-X XP125SD-M Owner's Manual.

4. Arrange the hi-hat stand, the kick pad, and the snare stand as shown in Example of standard assembly on the other side of this sheet.

NOTICE

- Lay a drum mat (sold separately) on the floor underneath the hi-hat stand and the kick pad. Alternatively, you can place cardboard from the drum kit packaging or the like on the floor to prevent it from being scratched.
- Ensure that you do not lower the electronic drum rack's center strut too much as doing so may cause it to come into contact with the kick pad.

5. Connect the pads to the drum trigger module.

As described below, connect the output of each pad to the corresponding trigger input jack on the drum trigger module.

1. Plug the straight ends of the ten-channel snake cable into the trigger input jacks on the back of the drum trigger module.
 - When using the standard setup, the stickers on each of the snake cable's plugs will indicate the name of the corresponding pad.
2. Plug the L-shaped ends of the ten-channel snake cable into the corresponding pads.
3. Wrap the cables for the snare pad, the tom pads, the cymbal pads and the hi-hat pad around the cable clips to prevent them from being pulled out.

NOTICE

Excessive bending can damage pad cables. Ensure, therefore, that these cables are not bent at an extreme angle when wrapped around the clips.

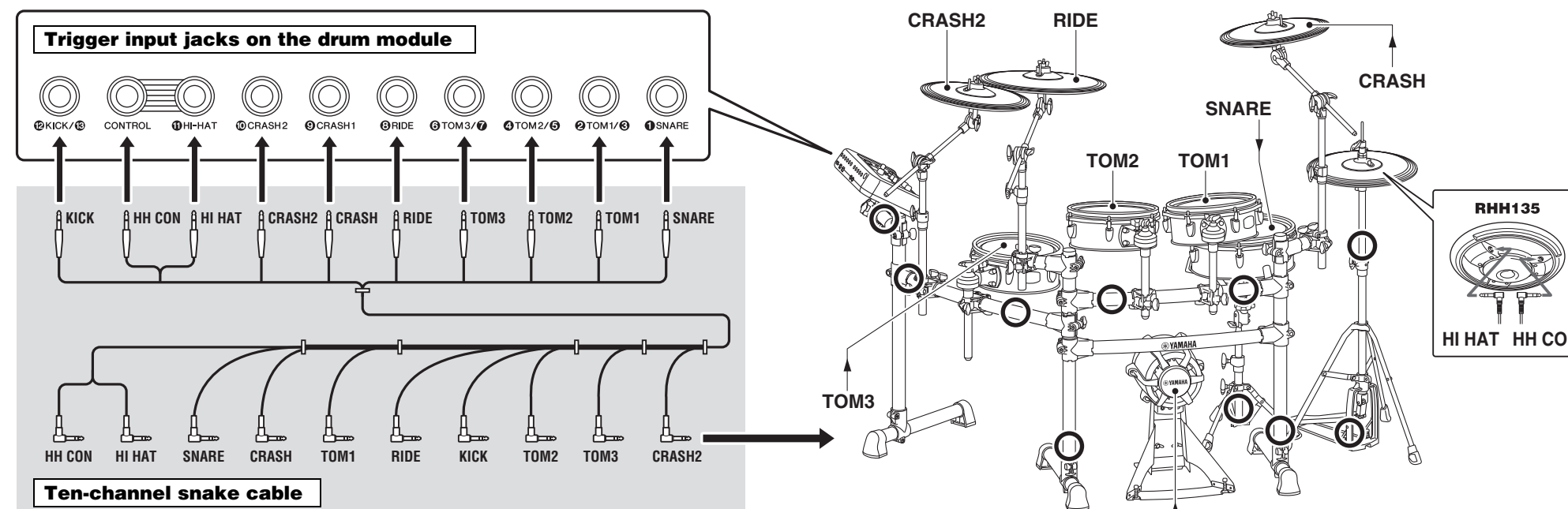

4. Using the cable bands, secure the cables to the electronic drum rack at the positions circled in the figure on the right. (○)



If you secure the cable band from the side closer to the drum trigger module, you can make connections more easily.

6. Connect the drum trigger module to a power supply.

1. Plug the AC adaptor's DC cord into the 12V connector. Hook the AC adaptor's DC cord around the cord clip to secure it in place.

CAUTION

Excessive bending can damage AC adaptor's DC cord. Ensure, therefore, that the cord is not bent at an extreme angle when wrapped around the clips. Doing so can cause fire or electrical shock.

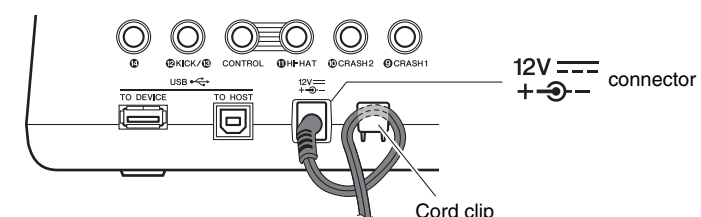

2. Plug the adaptor's AC cord into a domestic wall socket.

7. Setting up the drum trigger module.

According to your particular electronic drum kit, select the "DTX8K-X" or the "DTX8K-M" trigger set-up on your drum trigger module. (For details on the trigger setup procedure, refer to the "Initial Settings (Trigger Setup Wizard)" in the DTX-PRO Owner's Manual.)

IMPORTANT

The letters at the end of the model name ("X" or "M") indicates the pad type. "X" represents TCS products and "M" represents mesh products. Selecting the wrong trigger setup will adversely affect your ability to perform comfortably, since sensing when the drum is hit differs depending on the pad type. Use the correct trigger setup that corresponds to your particular electronic drum kit for optimum performance.

• Kick pad output (LEVEL) adjustment:

Adjust the trigger output to your desired setting by using the KP90 kick pad's level adjustment knob. For details, refer to the "Adjusting the Output Level" in the KP90 Owner's Manual.

IMPORTANT

- You can play comfortably by striking near the YAMAHA logo. Adjust the height, angle and orientation of the cymbal pad and hi-hat pad to a position where you can hit around the YAMAHA logo naturally when performing. The correct setting position is that the YAMAHA logo of the cymbal pad and hi-hat pad are visible in front of the performer. The direction of the cymbal pad will be appropriate by adjusting the direction of the stopper as shown on the right. The direction of the hi-hat pad will also be appropriate by adjusting the direction of the hi-hat clutch.
- The hi-hat shaft will become loose while you continue to use the hi-hat, and the hi-hat pad may rotate. Since this may adversely affect performance, screw in the hi-hat shaft periodically and adjust the position of the hi-hat pad.

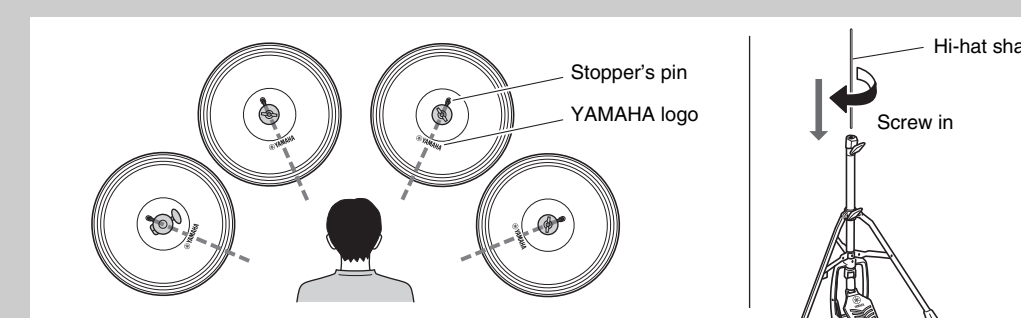

Your electronic drum kit is now ready.

* For instructions on turning on the drum trigger module, producing sounds, and other subsequent steps, refer to the Owner's Manual that came with the module.