

# YAMAHA

DYNAMIC PROCESSOR  
PROCESSEUR DYNAMIQUE  
DYNAMIKPROZESSOR

# DP100

Operation Manual  
Manuel d'instructions  
Bedienungsanleitung

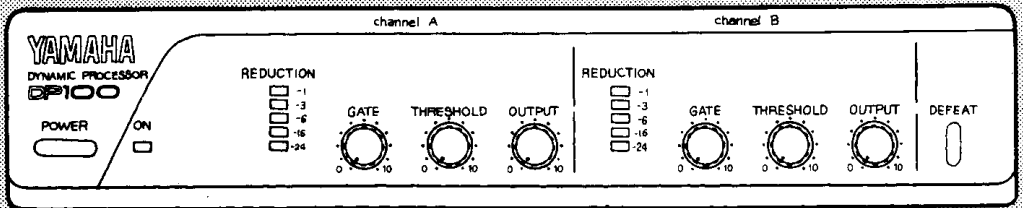

## **INTRODUCTION**

Thank you very much for purchasing the YAMAHA Dynamic Processor DP100.

The DP100 is a compact, half-rack sized unit which comprises a limiter circuit and a noise gate circuit in stereo configuration with two independent channels.

In order to exploit its potential to the fullest and for trouble-free operation for years to come we urge you to read this manual before attempting operation.

## **CONTENTS**

---

<b>FEATURES</b> .....	<b>2</b>
<b>PRECAUTIONS</b> .....	<b>2</b>
<b>NAMES AND FUNCTIONS OF PARTS</b>	
<b>FRONT PANEL</b> .....	<b>3/4</b>
<b>REAR PANEL</b> .....	<b>5</b>
<b>SPECIFICATIONS</b> .....	<b>6</b>
<b>DIMENSIONS</b> .....	<b>6</b>
<b>SYSTEM EXAMPLES</b> .....	<b>7/8</b>
<b>BLOCK DIAGRAM</b> .....	<b>9</b>

---

# FEATURES

---

- Distortions due to excessive input levels can be controlled by the limiter circuit, while residual noise (when there is no input) can be cut by the integrated noise gate circuit.
- Reduction indicators permit visual confirmation of the limiter effect.
- A DEFEAT switch allows bypassing the limiter and noise gate circuits to compare source sound and effect sound.
- Due to the 2-channel configuration throughout this unit can be connected to stereo equipment, but channels can be also used separately.
- INPUT and OUTPUT offer RCA pin jacks and phone plug jacks for connection. A LEVEL switch sets the input level to  $-10$  dB or  $-20$  dB to allow use with a wide range of PA, recording and audio equipment.
- Due to its compact half-rack size and light weight the DP100 fits anywhere and is easy to transport.

# PRECAUTIONS

---

- Always turn the power switch of other components (power amplifier, etc.) OFF before connecting them to this unit. Also, turn this unit ON first, and the power amplifier last.
- Use only the YAMAHA AC adaptor PA-1B or PA-5 or the power supply PW100. Connecting another power adaptor with different polarity or voltage may cause damage to the DP100.
- Avoid using the unit in locations like the following to prevent damage or trouble.
  - \* Places subject to direct sunlight, near heating devices, etc.
  - \* Places with extreme temperatures.
  - \* Excessively humid or dusty places.
  - \* Places subject to strong vibration.
- Do not apply force to switches and knobs.
- Do not open the case or tamper with the internal circuitry to prevent damage and the danger of electric jolts.
- Do not use benzine, thinner or solvents for cleaning the unit, and avoid spraying aerosol-type insecticides near it (they may cause discoloration, etc.)
- After reading this Operation Manual, keep it in a safe place.

# NAMES AND FUNCTIONS OF PARTS

## Front Panel

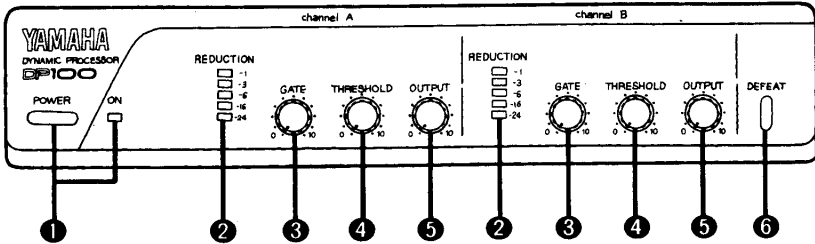

- 1 Power switch (POWER) and indicator**  
 When the POWER switch is ON ( — ) the ON indicator lights up.
- 2 Reduction indicators (REDUCTION)**  
 When the limiter circuit is activated these 5 LEDs display the reduction level for the input signals.
- 3 Gate level control (GATE)**  
 This control determines the gate level for the noise gate circuit. Sometimes disturbing noise and hum is generated when there is no input signal. To limit this noise set the gate level for the noise gate circuit with this control in order to shut off input signals below this level (noise gate closed). Signals above the set gate level, however, will be output (gate open).  
 Turn this control when there is no input signal until residual noise disappears.  
 \* The more you turn this control towards "10" the higher the gate level will become. A too high gate level will prevent a naturally fading sound and produce a sudden cut-off. Therefore, be careful when adjusting this control.

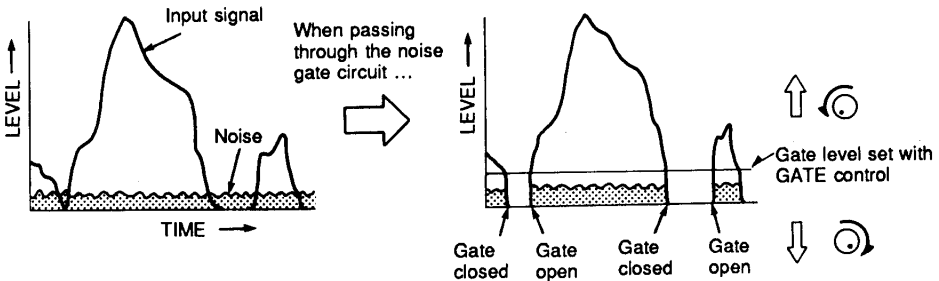

#### ④ Threshold level control (THRESHOLD)

This control adjusts the threshold level of the limiter circuit. An excessive input level will not only cause distortions but might also damage the speakers. The threshold level of the limiter circuit is set with this control and input signals above this level will be compressed. The level of the compressed signal will be displayed by the REDUCTION indicators ②. Set this control to a suitable position by checking the actual sound and the indicators.

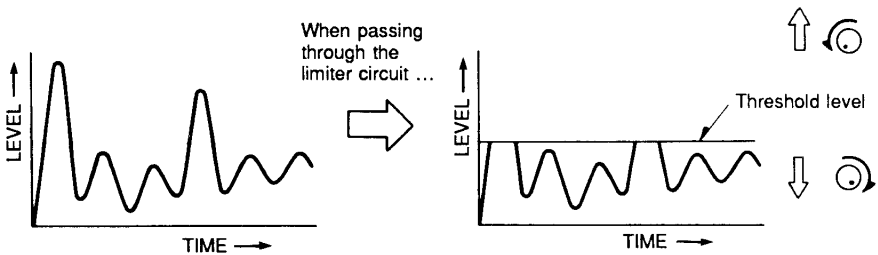

#### ⑤ Output level control (OUTPUT)

Sets the output level of the signals which have passed through the limiter circuit and the noise gate circuit. When the DEFEAT switch ⑥ is pressed ON ( — ) this control determines the output level of the input signal. Turning the control to the right will increase the output level.

#### ⑥ Defeat switch (DEFEAT)

This switch determines whether signals from the INPUT jacks will be processed by the limiter and the noise gate circuits or not.

When this switch is pressed ON ( — ) the settings of the GATE level control ③ and THRESHOLD level control ④ will have no effect. In this case the input signals will be delivered from the OUTPUT jacks with the level set by the OUTPUT level control ⑤. When the switch is OFF ( — ) the noise gate and limiter circuits operate. By pressing and releasing this switch you can check the effect of limiter circuit and noise gate circuit.

\* Since this switch applies to channel A and B simultaneously you can not switch the effects ON/OFF separately for one channel.

The circuits and controls are identical for both channels. Due to this 2-channel configuration you can use both channels A and B together or connect only one channel.

## Rear Panel

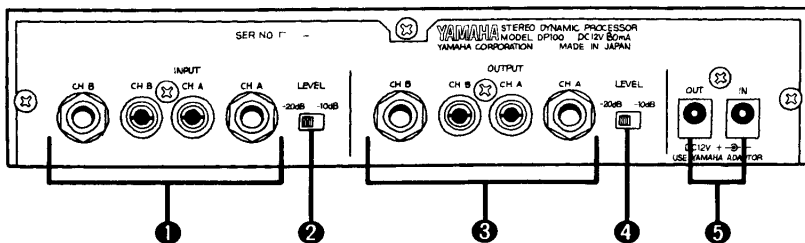

- 1 Input jacks (INPUT CH A, B)**  
These RCA pin jacks and phone jacks are the input terminals of the unit. Since the phone jacks have priority, no signal is delivered through the RCA pin jacks when there are plugs connected to the phone jacks.
- 2 Input level selector switch (LEVEL -20 dB/-10 dB)**  
To select the nominal input level for the input jacks between -20 dB and -10 dB. Set it according to the connected equipment's output level.
- 3 Output jacks (OUTPUT CH A, B)**  
These RCA pin jacks and phone jacks are the output terminals of the unit. Both can be used at the same time (the same signal is output through both).
- 4 Output level selector switch (LEVEL -20 dB/-10 dB)**  
To select the nominal output level of the output jacks between -20 dB and -10 dB. Set it according to the connected equipment's input level.
- 5 Power supply terminals (DC12V IN, OUT)**  
This unit requires a DC +12 V power supply. Connect the output cable of an AC adaptor or a cascade cable from the PW100 Power supply to this DC12V IN terminal.

\* Use only the YAMAHA AC adaptor PA-1B or PA-5 or the power supply PW100 for AC operation.

Using an AC adaptor other than these might cause damage to the unit.

The DC12V OUT terminal supplies DC +12 V power to suitable YAMAHA components like the MV100, the Q100, etc. However, the total current consumption of this unit (80 mA) and connected YAMAHA components must be within the maximum current supplied by the AC adaptor. For powering more than two devices we recommend the YAMAHA power supply PW100 with a maximum current yield of 2 A or the YAMAHA AC adaptor PA-5.

\* **Don't use a cascade arrangement for supplying power to the Reverb processor R100.**

# SPECIFICATIONS

Input terminals	: RCA pin jacks (CH A,B), phone jacks (CH A,B) Phone jacks have priority
Input level	: - 10 dB (245mV)/- 20 dB (77.5mV) switchable
Input impedance	: 10 kOhm
Output terminals	: RCA pin jacks (CH A,B), phone jacks (CH A,B)
Output level	: - 10 dB (245mV)/- 20 dB (77.5mV) switchable
Output impedance	: 600 Ohm
Gate level adjusting range	: - 60 dB — - 70 dB (at - 20 dB)
Threshold level adjusting range	: - 4 dB — - 44 dB (at - 20 dB)
Controls	: POWER switch, GATE level volume (CH A,B), THRESHOLD level volume (CH A,B), OUTPUT level volume (CH A,B), DEFEAT switch, input LEVEL selector switch (- 20 dB, - 10 dB), output LEVEL selector switch (- 20 dB, - 10 dB)
Indicators	: 5 LED reduction level indicators (- 1, - 3, - 6, - 16, - 24 dB: CH A,B)
Power Supply	: AC adaptor (DC +12 V) <OPTION>
Current Consumption	: 80 mA
Dimensions (W x H x D)	: 220 x 45.5 x 217 mm (8-11/16" x 1-13/16" x 8-9/16")
Weight	: 1.1 kg (2 lbs. 7 oz)
Standard Accessory	: DC Cascade power supply cable x 1

\* 0 dB = 0.775 Vrms

\* Specifications and design are subject to change without notice.

# DIMENSIONS

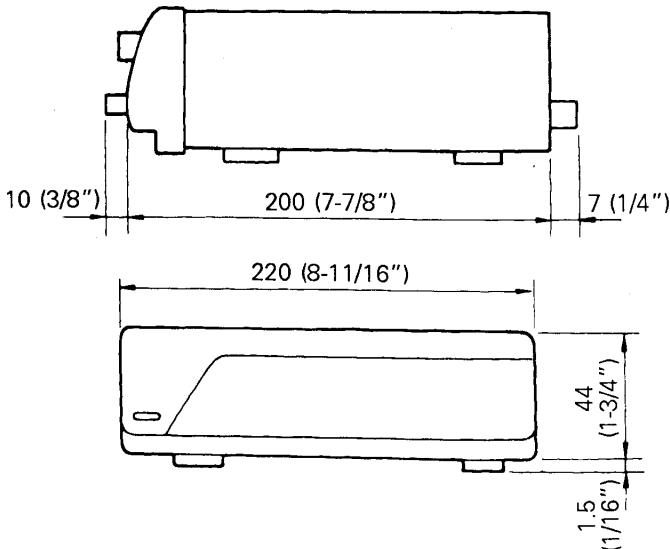

UNIT = mm (inch)

# SYSTEM EXAMPLES

## 1. Use with recording systems

The noise in the source signals mixed down by the MV100 will be cut and an even, clean sound for recording will result, while distortions due to excessive input levels will be prevented.

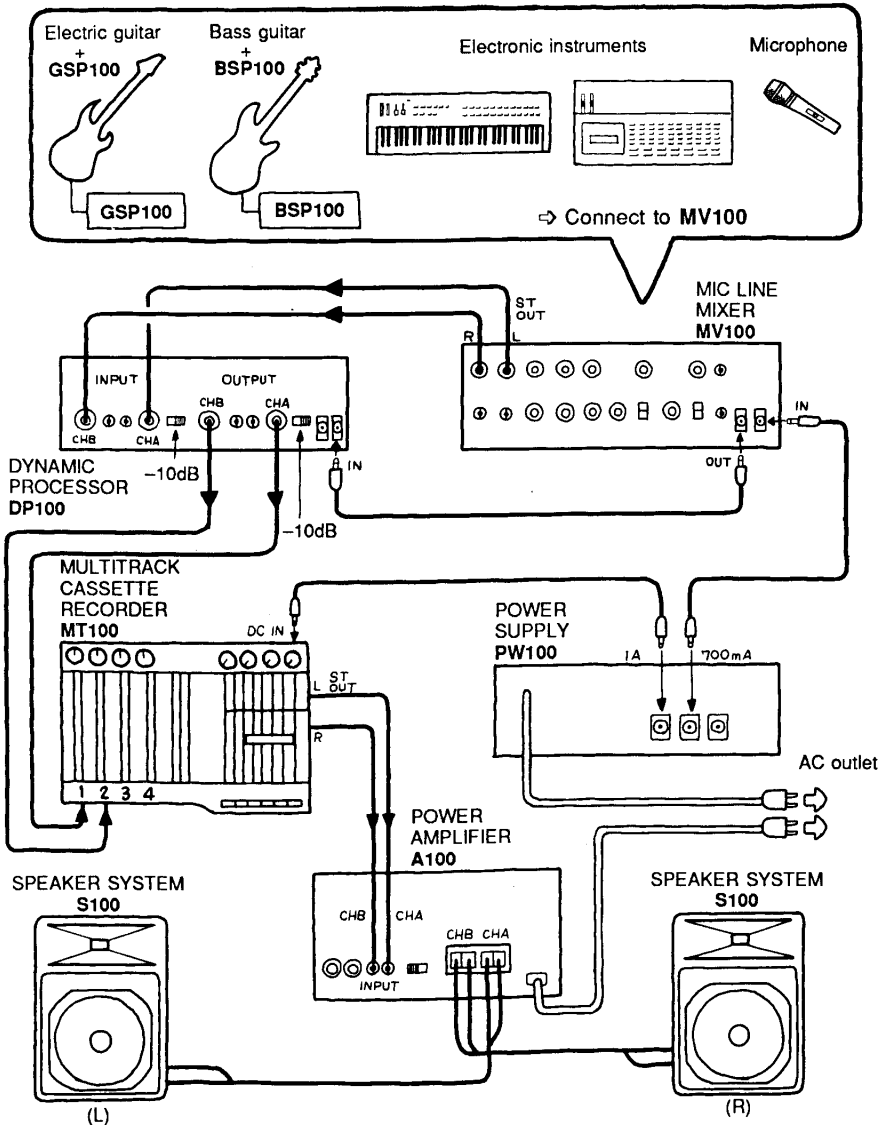



## 2. Use with PA systems

The limiter circuit will prevent damage to the speakers due to excessive input levels. Furthermore, the limiter effect will produce an even sound while the noise gate circuit will cut noise so that you can obtain a balanced, clean sound.

- The examples shows two cascade connected MV100s offering a total of 8 input channels

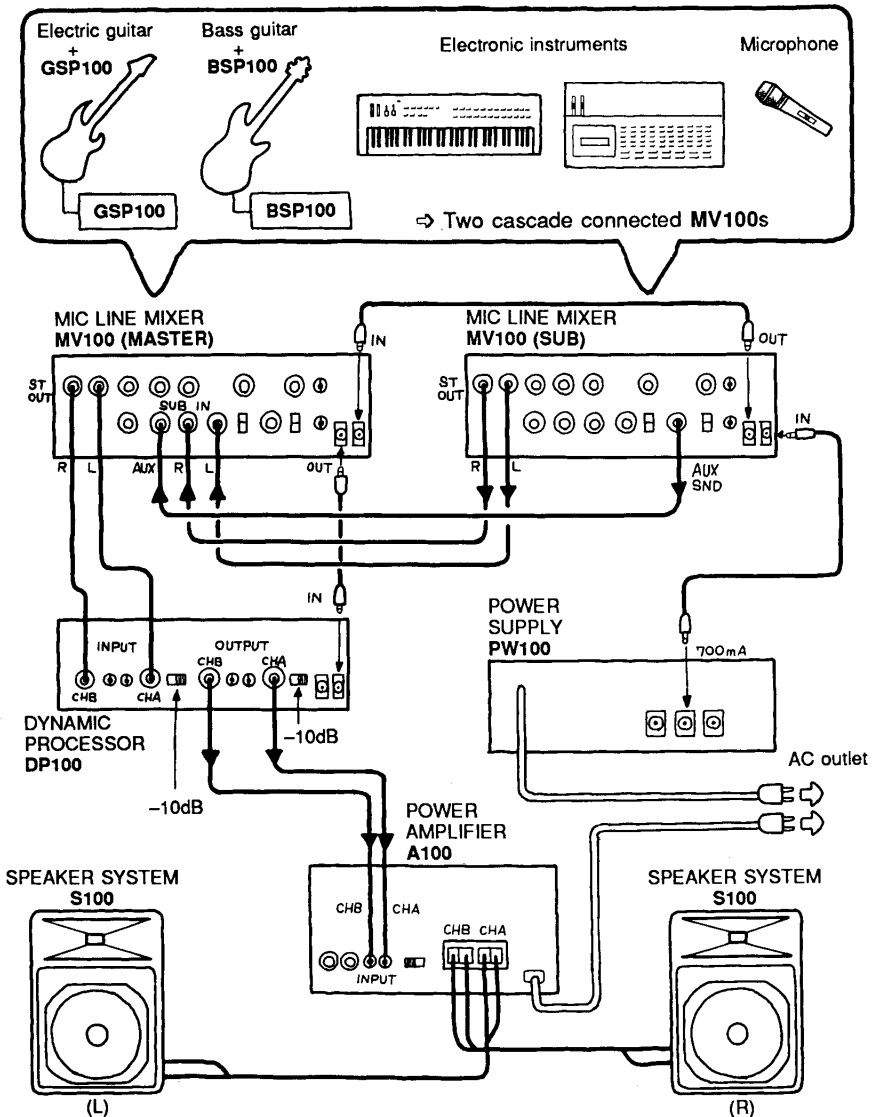

# BLOCK DIAGRAM

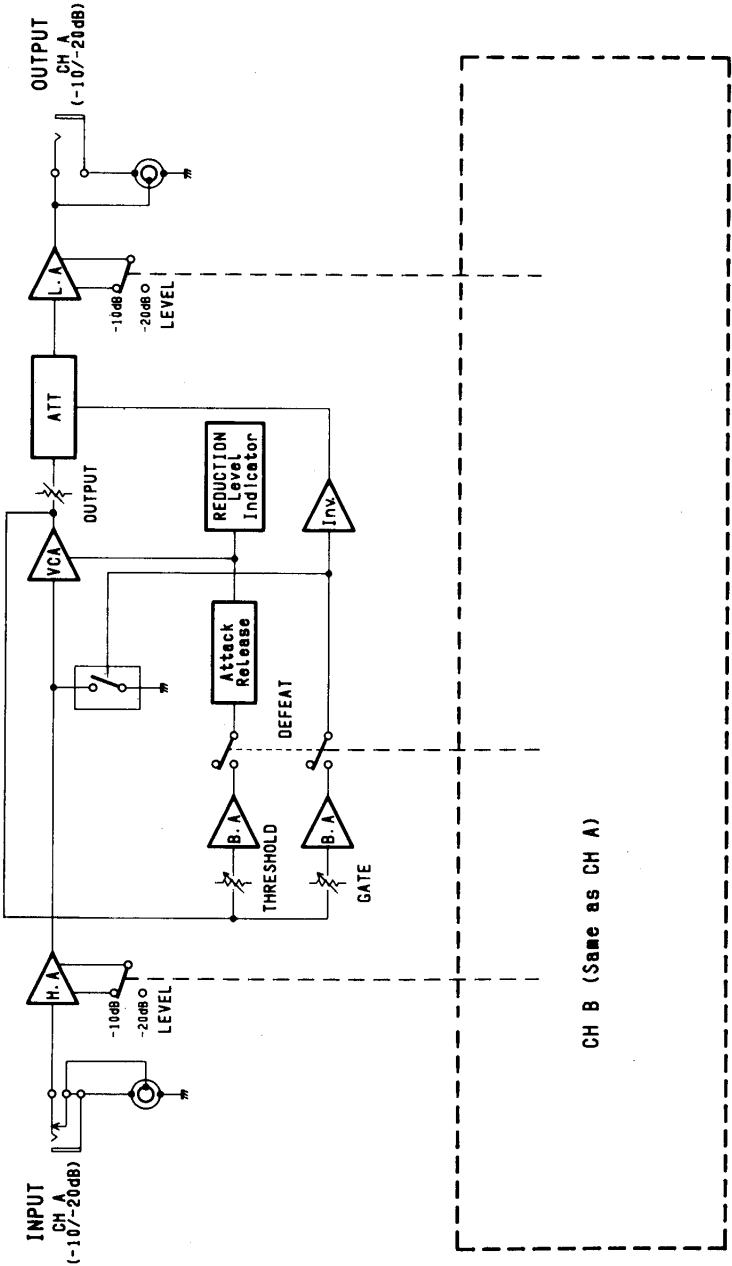

## ■ ACCESSORIES/ACCESSOIRES/ACCESSOIRES

- Rack Mount Kit / RK100, RK200
- Kits de montage en rack / RK100, RK200
- Rack-Einbausatz / RK100, RK200

- These provide space for 19" rack mounting of YAMAHA #100 series units.
- Ces Kits permettent le montage en rack de 19" d'appareils YAMAHA de la série 100.
- Dienen zum Einbau von YAMAHA-Geräten der Serie 100 in 19 Zoll Racks.

### RK100 (1U-Type / Type 1U / Typ 1U)

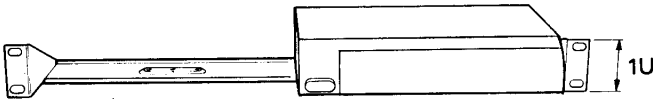

### RK200 (2U-Type / Type 2U / Typ 2U)

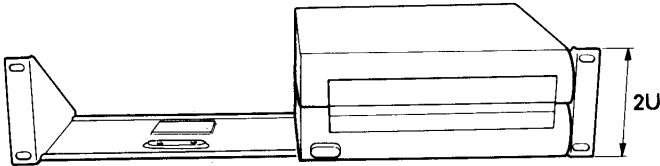

- Joint Metal / JK100
- Fixation / JK100
- Verbindungsstück / JK100

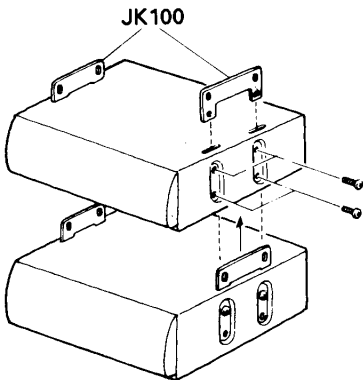

- An accessory for setting up YAMAHA #100 series units.
- Un accessoire servant à installer plusieurs appareils YAMAHA de la série 100.
- Zubehör zum Aufeinanderstapeln von mehreren YAMAHA-Geräten der Serie 100.