

OWNER'S MANUAL

GUITAR AMPLIFIERS

15
25
35
55
65

VX SERIES

BASS AMPLIFIERS

25
35
55

INTRODUCTION

All the amplifiers in this series have been specifically designed to provide the best sound for contemporary guitar and offer a number of unique features that give you total control over your sound. In addition, they are sturdily constructed of the finest materials in Yamaha's tradition of excellent craftsmanship, so you're guaranteed superb performance and responsiveness even through the toughest use.

Please read this Owner's Manual carefully in order to fully realize the potential of the unit and to keep it in best condition for many years of trouble-free use.

CAUTION

- Check for correct voltage before connecting the power cord to your AC outlet.
- When connecting the electric guitar and the amplifier, make sure to plug in the guitar before plugging in the amplifier. Plugging in the amplifier first may cause damage to the speaker.
- Be sure to turn the MASTER VOLUME (VOLUME control on bass amplifiers) control of the amplifier counter-clockwise to its minimum position when plugging or unplugging the guitar cord and turning the power supply ON and OFF.
- Always handle the amplifier with care. Rough handling or dropping it may result in deterioration of its performance.
- Disconnect the power cord from the AC outlet whenever there is thunderstorm to prevent accidents that may result from lightning.

GUITAR AMPLIFIERS

PANEL OPERATION

FRONT PANEL

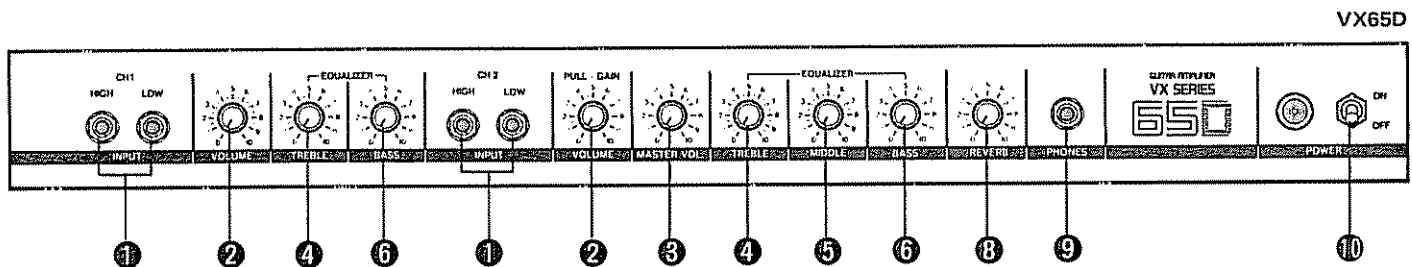
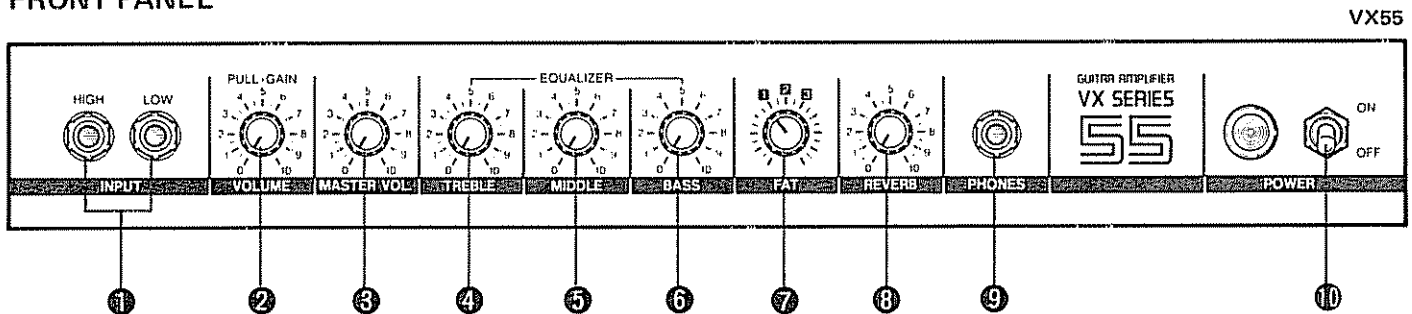

REAR PANEL

VX65D (General model)

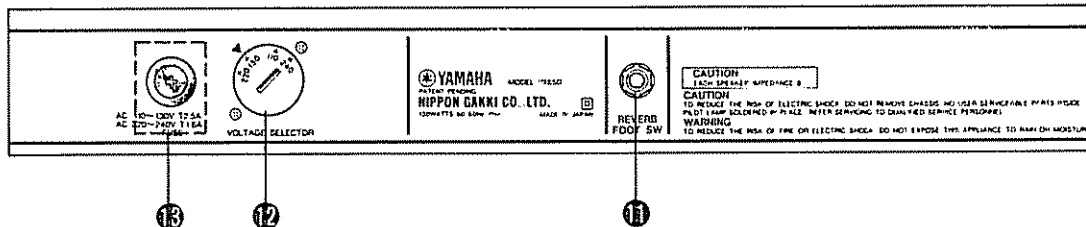

① INPUT

HIGH: The HIGH INPUT provides high sensitivity for a powerful, bright sound, and should be used with low to medium level output guitars. The HIGH INPUT also provides the best sound when distortion is required.

LOW: The LOW INPUT gives a softer, rounder sound with no distortion. Perfect for jazz and "mellow" guitar styles. This input should be used with high level output guitars and electronic keyboard instruments such as synthesizers, combo organs, etc.

* When two guitars are plugged simultaneously in HIGH and LOW INPUT jacks, high sensitivity will be provided for both of them.

② VOLUME

VX15, 25, 35, 55 & 65D CH2

This control alters volume level as well as sound quality. Used in conjunction with the MASTER VOLUME control, it lets you create a wide variety of sounds from super clean to smoothly distorted.

VX65D CH1

This control alters output level of CH1. Turning it clockwise increases the volume.

* PULL-GAIN/VOLUME (except VX15 & VX65D CH1)

Pull the knob out, and the gain is increased with a corresponding increase in distortion. This setting gives a smooth overdrive sound that is ideal for contemporary rock and "crossover" styles.

* No sound is heard with this control set to "0" position.

③ MASTER VOLUME

The MASTER VOL. control lets you adjust the overall output level without greatly affecting sound quality. With the MASTER VOL. control at a relatively high setting, and the PULL GAIN/VOLUME control at a low setting, the sound is crisp and clear. Lower the MASTER VOLUME level and raise the PULL GAIN/VOLUME level, and you get a "funkier" distorted sound.

* No sound is heard with this control set to "0" position.

EQUALIZER

④ TREBLE

The equalizer TREBLE control affects the high frequency range. Turned in the clockwise direction, this control creates a bright "metallic" sound for a bright solo guitar sound. Turned in the counterclockwise direction, the sound is rounder, and more suited to mellow jazz style single note playing.

⑤ MIDDLE (VX35, VX55 & VX65D CH2)

The MIDDLE control lets you boost or cut the mid frequency range. When the middle range is boosted, the sound is full and powerful letting lead and melody lines stand out strongly. When this range is cut, the sound is thin and light excellent for chord accompaniment.

⑥ BASS

The BASS control determines the "heaviness" of the sound. Turning the BASS control clockwise produces a heavier sound, while turning it counterclockwise produces a clearer, lighter sound.

* In the VX35, VX55 and CH2 of the VX65D, no sound is heard with TREBLE, MIDDLE and BASS controls set to their minimum position.

⑦ FAT (VX55 Only)

The FAT control gives extra boost to the middle frequency range for an exceptionally powerful, "up-front" sound that gives you plenty of carrying power for lead and melodic runs. Positions "1", "2" and "3" provide varying degrees of "FATness", "3" is maximum.

⑧ REVERB

The REVERB control creates a gradual increase in ambience. Similar to an echo effect, reverb can alter the apparent "distance" of the sound. Turning the control clockwise increases the effect, while turning it counterclockwise decreases the effect until at position "0" the reverb sound is completely cancelled.

⑨ PHONES (VX15 rear panel)

The PHONE jack lets you practice in private using a pair of standard headphones. This is particularly useful when you practice late at night and want to keep the peace with your neighbors, and also makes it convenient to tune your instrument in a noisy environment: i.e. backstage before a live performance.

* When the headphones are plugged in this jack, no sound is heard from the speakers.

⑩ POWER

The POWER switch turns the mains power to the amplifier ON and OFF. Power is indicated by a red pilot lamp. When such electronic keyboard instruments as synthesizers are connected, be sure to turn on the amp POWER switch last before playing and turn it off first after playing so as to prevent damage to the speakers.

⑪ REVERB FOOT SWITCH (VX55 & VX65D)

The VX55 and VX65D features rear-panel jack for an accessory foot switch that lets you turn the reverb effect ON and OFF with a tap of your toe.

⑫ VOLTAGE SELECTOR (General model only)

Set this to your local AC mains voltage. Failure to do so will result in seriously impaired performance or even severe damage.

⑬ FUSE

When replacing the fuse, be sure to first disconnect the AC cord from the outlet. Replace only with a fuse of the same type. If the fuse blows during use of the amplifier, this can be due to mishandling or to an internal defect. In such a case, contact your dealer.

* The VX25 and VX65D have rear panel fuse holders.

The VX35 and VX55, however are internally fused necessitating removal of the upper wooden panel for fuse replacement. The VX15 has no fuse.

SPECIFICATIONS

	VX15	VX25	VX35
Output Power	10 Watts rms @ 10% THD into 4Ω	20 Watts rms @ 3% THD into 8Ω	30 Watts rms @ 3% THD into 8Ω
Speaker	1 x JA2108 8" (20 cm)	1 x JA2531 10" (25 cm)	1 x JA3110 12" (30 cm)
Input	HIGH GAIN, LOW GAIN	HIGH GAIN, LOW GAIN	HIGH GAIN, LOW GAIN
Input Sensitivity**	High -62 dB* (0.6 mV) Low -48 dB* (3 mV) f = 1 kHz, Volumes & Tone Controls at max	Normal High -41 dB* (7 mV) Low -29 dB* (27 mV) Pull Gain High -60 dB* (0.8 mV) Low -48 dB* (3 mV) f = 1 kHz, Volumes & Tone Controls at max	Normal High -39 dB* (9 mV) Low -27 dB* (35 mV) Pull Gain High -56 dB* (1.0 mV) Low -46 dB* (4 mV) f = 1 kHz, Volumes & Tone Controls at max
Noise***	-20 dB* (Vol max M. Vol max) -63 dB* (Vol max M. Vol min)	-23 dB* (Vol max M. Vol max Pull-G Pull) -37 dB* (Vol max M. Vol max Pull-G Push) -55 dB* (Vol max M. Vol min Pull-G Pull)	
Reverb	Spring Type YAMAHA JH00021	Spring Type YAMAHA JH00012	
Controls	Volume, M. Volume, Treble, Bass, Reverb, Power Switch	Volume (Pull Gain), M. Volume, Treble, Bass, Reverb, Power Switch	Volume (Pull Gain), M. Volume, Treble, Middle, Bass, Reverb, Power Switch
Headphone Jack Level	-8 dB* (0.3V) @ 10W (Headphone Impedance 8Ω)	-8 dB* (0.3V) @ 20W (Headphone Impedance 8Ω)	-8 dB* (0.3V) @ 30W (Headphone Impedance 8Ω)
Power Consumption U.S. & Canadian Models General Models	20 Watts 30 Watts	30 Watts 50 Watts	40 Watts 65 Watts
Power Requirement U.S. & Canadian Models General Models	120V 60 Hz 110, 130, 220, 240V 50/60 Hz		
Dimensions (W) x (H) x (D)	361 x 322 x 207 mm 14-1/4" x 12-5/8" x 8-1/8"	433 x 393 x 207 mm 17" x 15-1/2" x 8-1/8"	486 x 452 x 207 mm 19-1/8" x 17-3/4" x 8-1/8"
Weight	6.8 kg (15.0 lbs.)	10.4 kg (22.9 lbs.)	12.4 kg (27.3 lbs.)
Cabinet	Sturdy Particleboard		
Finish	Black Leatherette		

	VX55	VX65D
Output Power	50 Watts rms @ 3% THD into 8Ω	60 Watts rms @ 3% THD into 4Ω
Speaker	1 x JA3111 12" (30 cm)	2 x JA3110 12" (30 cm)
Input	HIGH GAIN, LOW GAIN	ch 1 HIGH GAIN, LOW GAIN ch 2 HIGH GAIN, LOW GAIN
Input Sensitivity**	Normal High -37 dB* (11 mV) Low -25 dB* (44 mV) Pull Gain High -56 dB* (1.2 mV) Low -44 dB* (5 mV) f = 1 kHz, Volumes & Tone Controls at max	ch 1 High -39 dB* (9 mV) Low -27 dB* (35 mV) ch 2 Normal High -39 dB* (9 mV) Low -27 dB* (35 mV) Pull Gain High -58 dB* (1.0 mV) Low -46 dB* (4 mV) f = 1 kHz, Volumes & Tone Controls at max
Noise***	-23 dB* (Vol max M. Vol max Pull-G Pull) -37 dB* (Vol max M. Vol max Pull-G Push) -55 dB* (Vol max M. Vol min Pull-G Pull)	-23 dB* (ch 1 Vol max, ch 2 Vol max, M. Vol max, Pull-G Pull) -35 dB* (ch 1 Vol max, ch 2 Vol max, M. Vol max, Pull-G Push) -35 dB* (ch 1 Vol min, ch 2 Vol max, M. Vol max, Pull-G Push) -55 dB* (ch 1 Vol min, ch 2 Vol max, M. Vol min, Pull-G Pull)
Reverb	Spring Type YAMAHA JH00012	
Controls	Volume (Pull Gain) M. Volume, Treble, Middle, Bass, Fat, Reverb, Power Switch	ch 1 Volume, Treble, Bass ch 2 Volume (Pull Gain), M. Volume, Treble, Middle, Bass, Reverb, Power Switch
Foot Sw Jack	Reverb ON/OFF	Reverb ON/OFF
Headphone Jack Level	-8 dB* (0.3V) @ 50W (Headphone Impedance 8Ω)	-8 dB* (0.3V) @ 60W (Headphone Impedance 8Ω)
Power Consumption U.S. & Canadian Models General Models	75 watts 120 watts	80 watts 130 watts
Power Requirement U.S. & Canadian Models General Models	120V 60 Hz 110, 130, 220, 240V 50/60 Hz	
Dimensions (W) x (H) x (D)	521 x 452 x 207 mm 20-1/2" x 17-3/4" x 8-1/8"	680 x 557 x 306 mm 26-3/4" x 21-7/8" x 12"
Weight	14.5 kg (32.0 lbs.)	22.4 kg (49.4 lbs.)
Cabinet	Sturdy Particleboard	
Finish	Black Leatherette	

*0 dB is referenced to 775mV rms/ ** at 1 kHz, VOLUME and all EQ CONTROLS at max/ ***input short
All specifications subject to change without notice or obligation.

■ BLOCK DIAGRAM

VX15, VX25, VX35, VX55

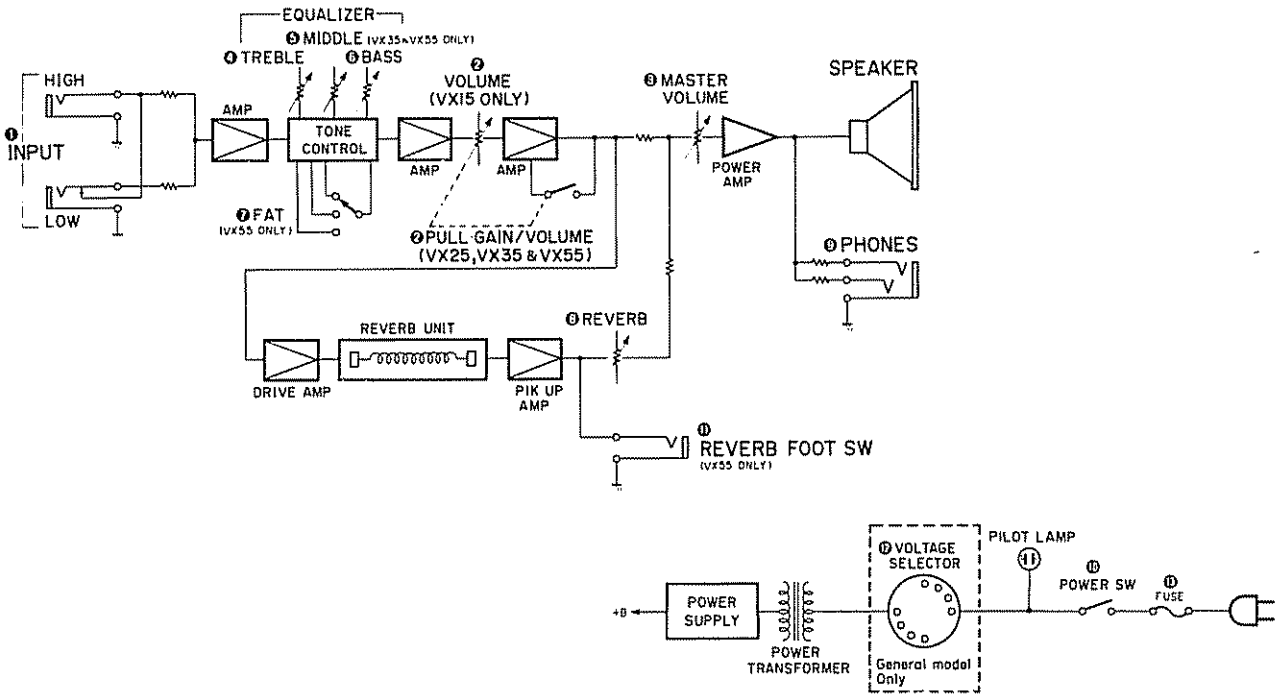

VX65D

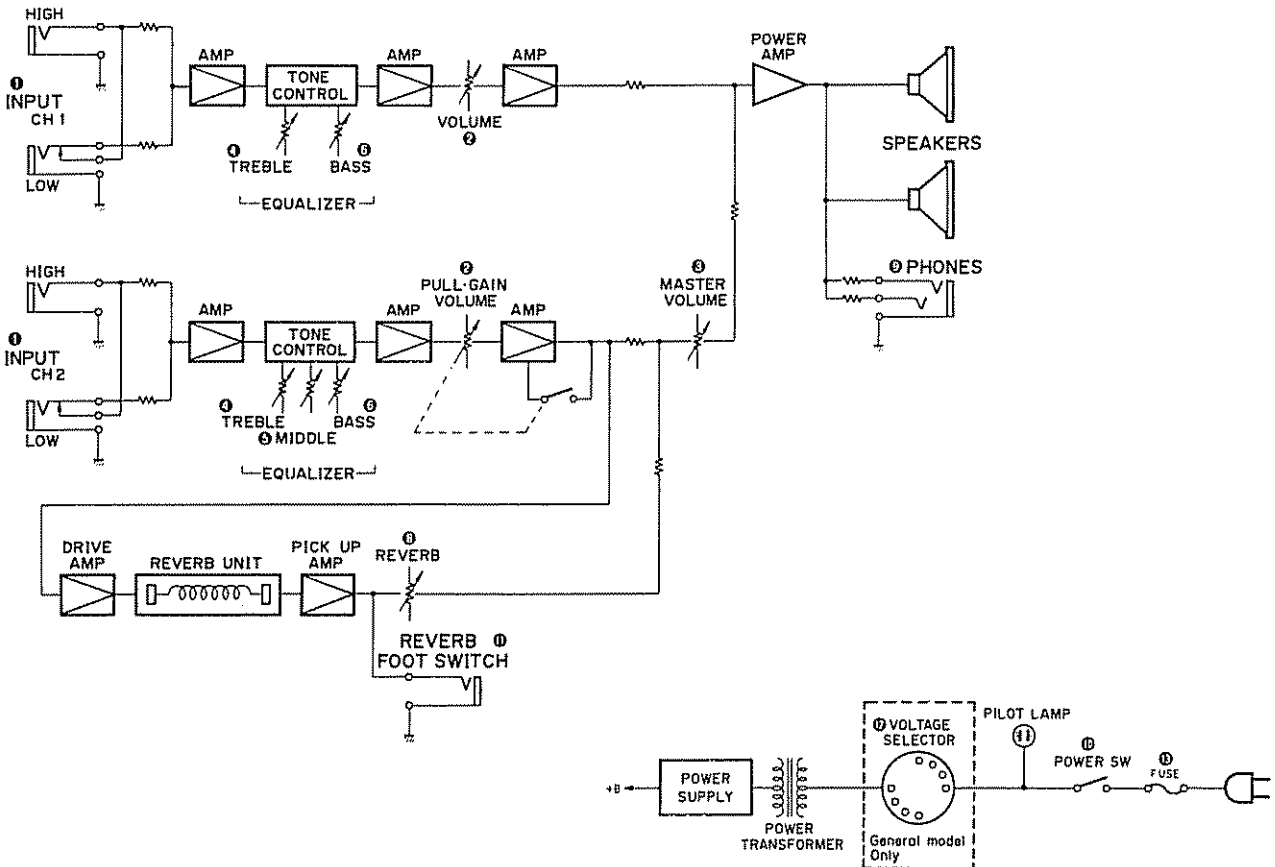

BASS AMPLIFIERS

PANEL OPERATION

FRONT PANEL

VX55B

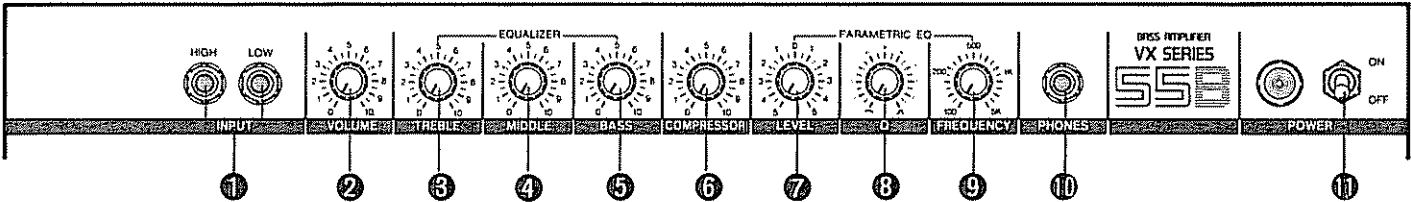

REAR PANEL

VX55B (General model)

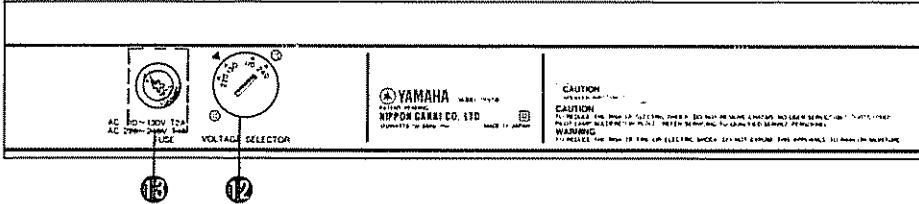

① INPUT

HIGH: Plugging into the High sensitivity input jack results in a full, powerful bass sound that gives maximum impact with low and medium output basses.

LOW: The Low input jack provides a more mellow, subtle bass sound. High output basses should be plugged into this jack.

② VOLUME

Turning the Volume control clockwise increases the overall output level of the amplifier. Counterclockwise rotation decreases output level.

EQUALIZER

③ TREBLE

The Treble control affects the high frequencies. A bright, funky sound is achieved by turning this control up. Turning it down results in a softer, smoother sound.

④ MIDDLE

This control affects the "presence" of the sound. Rotated clockwise, the sound comes forward with plenty of power and punch. Rotated counterclockwise, the sound is lighter and less predominant.

⑤ BASS

This control boosts or cuts the lower frequencies. Rotated clockwise, the sound is solid and heavy. Rotated counterclockwise, the sound is more "airy" ideal for fast-moving bass lines.

* No sound is heard with all of TREBLE, MIDDLE and BASS controls turned to their minimum position.

⑥ COMPRESSOR (VX35B & VX55B only)

Turning this control clockwise causes large input signals to be compressed and small inputs to be amplified. This allows the use of a very long sustain with no distortion. Very useful for funky bass lines played with a heavy attack. When not being used, turn the knob to "O" position to prevent noise or howling.

PARAMETRIC EQUALIZER (VX55B only)

⑦ LEVEL

Turning this knob clockwise causes a peak at the frequency selected by the FREQUENCY knob, emphasizing this frequency region. Turning the knob counterclockwise causes a dip, deemphasizing the selected frequency region. When this knob is at center position (clickstop at 0), no effect is obtained, regardless of the positions of the Q and FREQUENCY knobs.

⑧ Q

This knob adjusts the width of the frequency band being equalized. If turned clockwise towards (∞), a sharper characteristic is obtained, narrowing the influenced sound range.

⑨ FREQUENCY

This knob adjusts the frequency to be influenced. The markings show the center frequency of the peak or dip.

⑩ PHONES

The headphone jack lets you practice in private via a pair of standard headphones. This is particularly useful when you practice late at night and want to keep the peace with your neighbours, and makes it convenient to tune your instrument in a noisy environment: i.e. backstage before a performance.

* When the headphones are plugged in this jack, no sound is heard from the speakers.

⑪ POWER

The Power switch turns the mains power to the amplifier off or on. Power is indicated by a red pilot lamp.

⑫ VOLTAGE SELECTOR (General model only)

Set this to your local AC mains voltage. Failure to do so will result in seriously impaired performance or even severe damage.

⑬ FUSE

When replacing the fuse, be sure to first disconnect the AC cord from the outlet. Replace only with a fuse of the same type. If the fuse blows during use of the amplifier, this can be due to mishandling or to an internal defect. In such a case, contact your dealer.

* The VX25B rear panel must be removed for fuse replacement.

SPECIFICATIONS

	VX25B	VX35B	VX55B
Output Power	30 Watts rms @ 3% THD into 8Ω	30 Watts rms @ 3% THD into 8Ω	50 Watts rms @ 3% THD into 8Ω
Speaker	1 x JA3111 12" (30 cm)	1 x JA3811 15" (38 cm)	1 x JA3811 15" (38 cm)
Input	HIGH GAIN, LOW GAIN	HIGH GAIN, LOW GAIN	HIGH GAIN, LOW GAIN
Input Sensitivity**	High -39 dB* (9 mV) Low -27 dB* (35 mV) f = 1 kHz, Volume & Tone Controls at max	High -39 dB* (9 mV) Low -27 dB* (35 mV) f = 1 kHz, Volume & Tone Controls at max	High -37 dB* (11 mV) Low -25 dB* (44 mV) f = 1 kHz, Volume & Tone Controls at max
Noise***	-35 dB (Volume max) -55 dB (Volume min)		
Controls	Volume, Treble, Middle, Bass, Power Switch	Volume, Treble, Middle, Bass, Compressor, Power Switch	Volume, Treble, Middle, Bass, Compressor, Parametric Equalizer (Level, Q, Frequency), Power Switch
Headphone Jack Level	-8 dB* (0.3V) @ 30W (Headphone Impedance 8Ω)	-8 dB* (0.3V) @ 30W (Headphone Impedance 8Ω)	-8 dB* (0.3V) @ 50W (Headphone Impedance 8Ω)
Power Consumption U.S. & Canadian Models General Models	40 watts 65 watts	40 watts 65 watts	75 watts 120 watts
Power Requirement U.S. & Canadian Models General Models	120V 60 Hz 110, 130, 220, 240V 50/60 Hz		
Dimensions (W) x (H) x (D)	486 x 452 x 207 mm 19-1/8" x 17-3/4" x 8-1/8"	538 x 692 x 306 mm (*) 21-1/8" x 27-1/4" x 12" 538 x 637 x 306 mm (**) 21-1/8" x 25-1/8" x 12"	608 x 727 x 306 mm (*) 23-7/8" x 28-5/8" x 12" 608 x 732 x 306 mm (**) 23-7/8" x 28-7/8" x 12"
Weight	13.0 kg (28.7 lbs.)	26.0 kg (57.3 lbs.) (*) 24.4 kg (53.8 lbs.) (**)	30.0 kg (66.0 lbs.) (*) 30.3 kg (66.7 lbs.) (**)
Cabinet	Sturdy Particleboard		
Finish	Black Leatherette		

*0 dB is referenced to 775 mV rms/** at 1 kHz, VOLUME and all EQ CONTROLS at max/** input short
All specifications subject to change without notice or obligation.

(*) Canadian & General Model
(**) U.S. Model

BLOCK DIAGRAM

VX25B, VX35B, VX55B

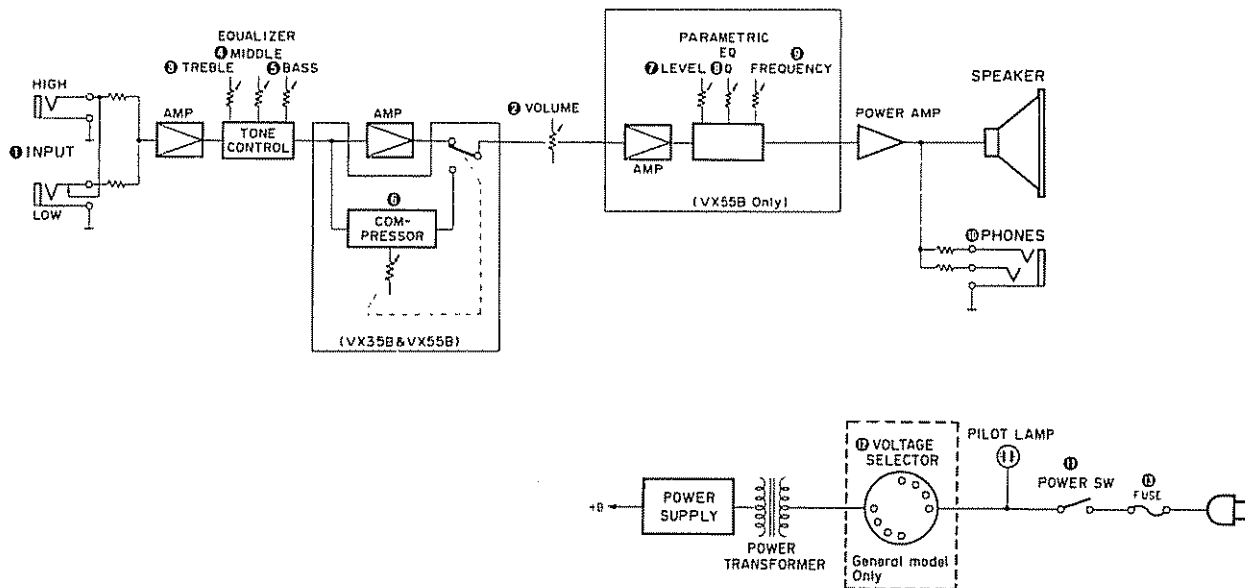

SINCE 1887  **YAMAHA**
NIPPON GAKKI CO., LTD. HAMAMATSU, JAPAN